

TYPICAL DECEL SECTION WITH CURB AND GUTTER
N.T.S.

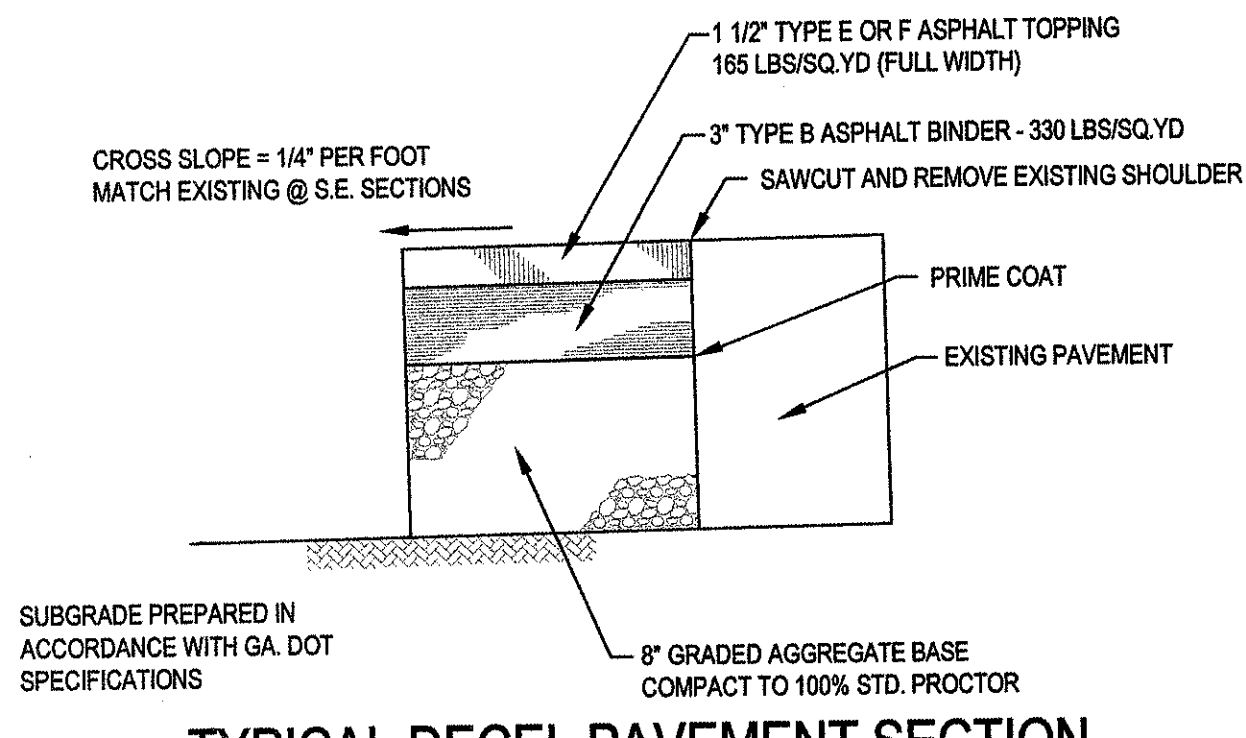

TYPICAL DECEL PAVEMENT SECTION
N.T.S.

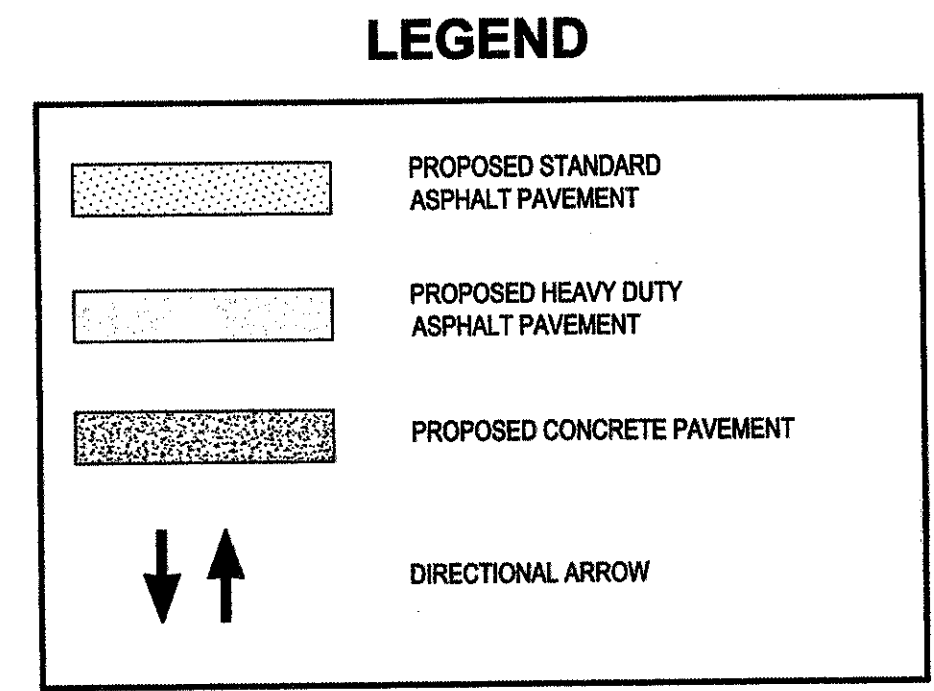
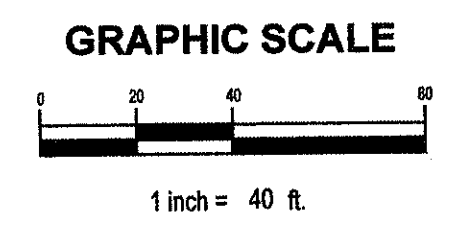

N/F
DESTINY VENTURES, INC.
D.B. 2729 PG. 624
P.B. 88 PG. 205
046 5127 048
ZONED: RC

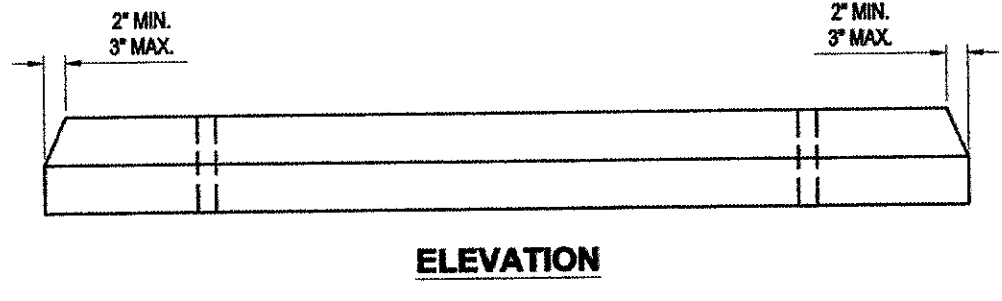
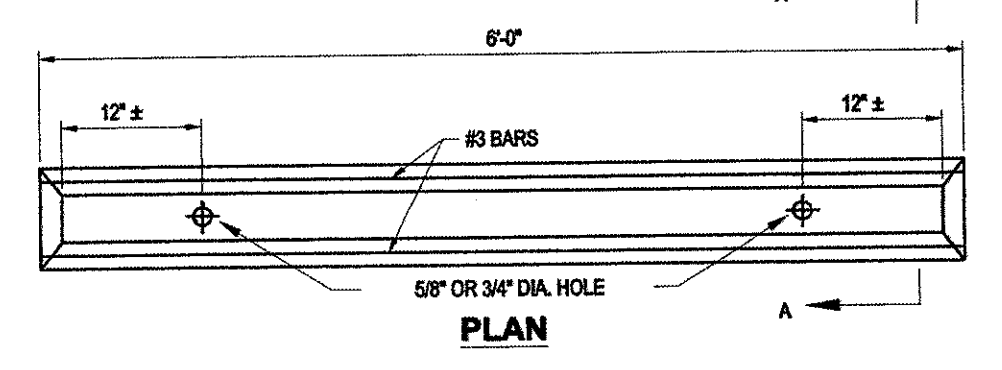
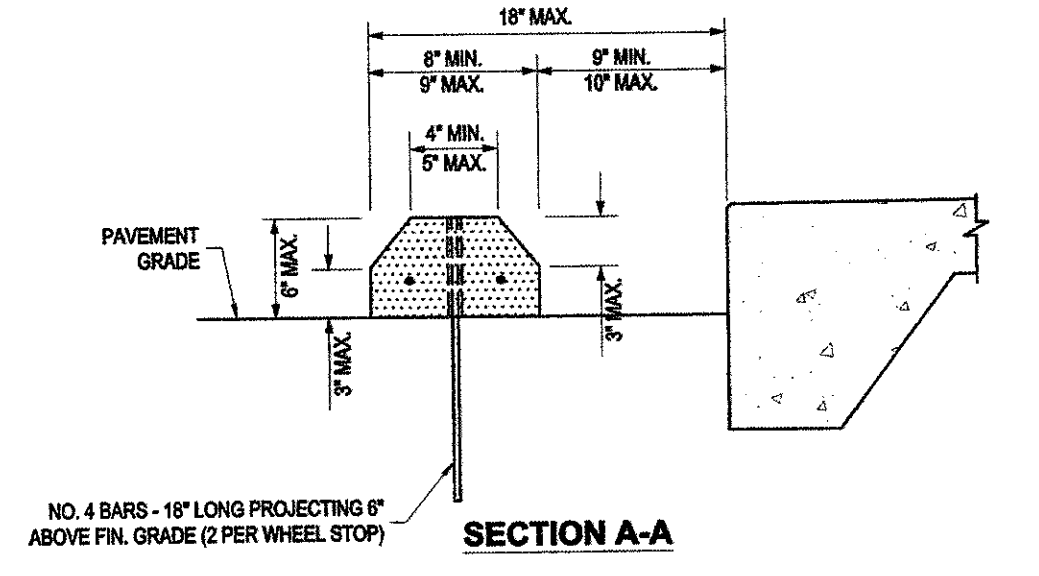

WHEEL STOP DETAIL
NOT TO SCALE

Moore Bass
ATLANTA
DESTIN
TALLAHASSEE
NEWMIAMI
www.moorebass.com
(770) 251-9800
(770) 251-9801

PROJECT NAME
SARGENT PLAZA
CLIENT NAME
SARGENT PLAZA, LLC
1775 GRAHAM AVENUE, SUITE 201
HENDERSON, NORTH CAROLINA 27636

REVISIONS
3/31/08 - REVISED PER COMETA COUNTY COMMENTS



J463-cd-geo.dwg
ARCHIVE
DATE 2/14/08
FILE # 07-436
CONTRACT # J46.003

DRAWN BY JSA
The Drawings, Specifications and other documents prepared by Moore Bass Consulting, Inc. (MBC) for this Project are instruments of professional service. They shall be used only for the Project and site for which they are prepared. They shall not be used for any other Project or site without the written consent of Moore Bass Consulting, Inc. The user shall retain all common law, statutory and other reserved rights, including the copyright.

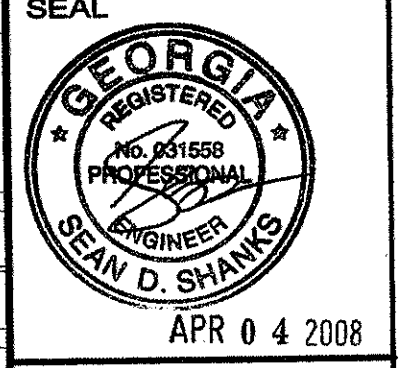

APR 04 2008
SHEET TITLE
GEOMETRY PLAN
SHEET
4.0

C:\projects\1463\1463\1463-geo.dwg 4.0 Site Geometry Plan, submittal, Apr 04, 2008, 12:01:09pm
© Moore Bass Consulting